



Clean Air Power
 13615 Stowe Drive
 Poway, CA 92064, USA
 +1 858 332 4800
www.cleanairpower.com

Natural Gas Shut Off Valve

Part Number 619260

Features

Pressure rating	Working pressure 1400 kPa
Operating Voltage	12 VDC
Operating Temperature Range	-40 to +120°C
Orifice Diameter	7/16"
O-Ring Material	Nitrile



Shut Off Valve

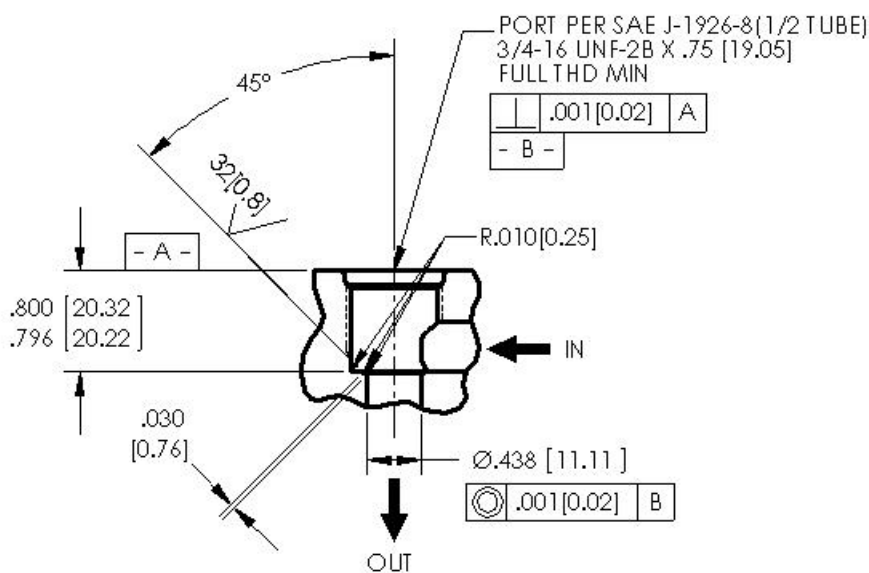
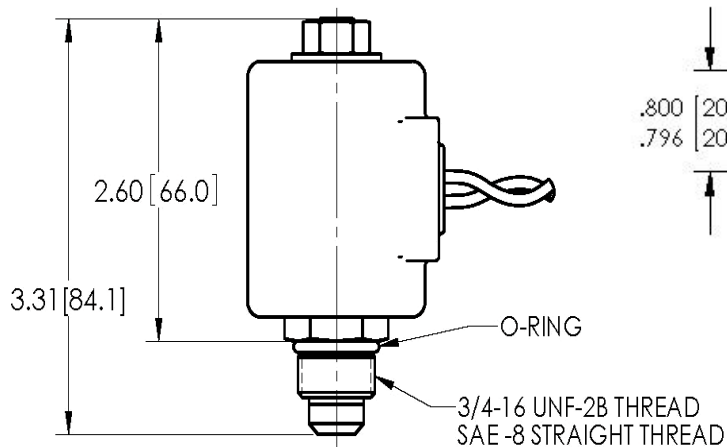

Mating Valve Seat Details



Natural Gas Shut Off Valve

Part Number 619260

Shut Off Valve & Block

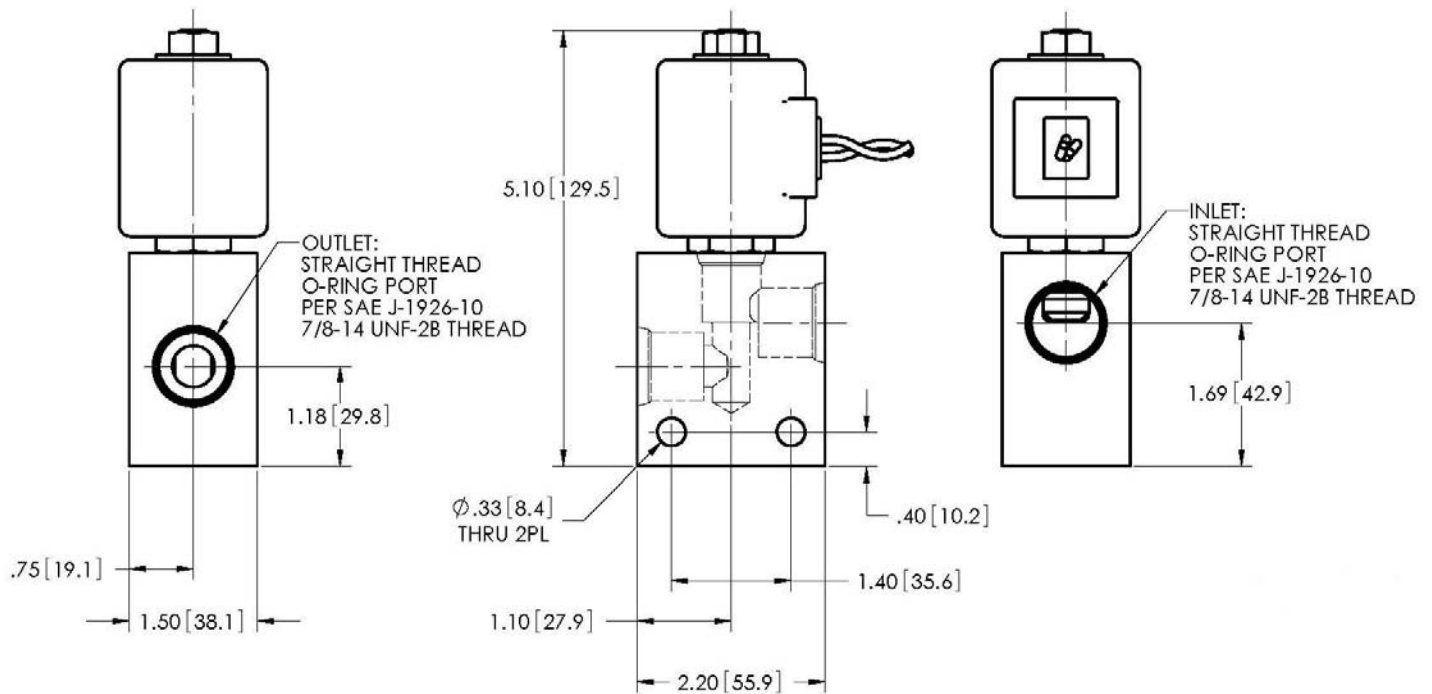

Ordering Information

Part Number	Item	Body Material	O-ring Material	Coil Type	Coil Resistance (ohms)	Connector	Lead wires
619260-1	Normally Closed Valve	Brass	Nitrile	Flying leads	7.2 @ 20 deg. C	PED 1201 0973	18 ga. x 10 [254] XLP insulation with acrylic coated fiberglass sleeving
619260-2	Normally Closed Valve	Stainless Steel	Nitrile	Flying leads	7.2 @ 20 deg. C	PED 1201 0973	18 ga. x 10 [254] XLP insulation with acrylic coated fiberglass sleeving
619849-1	Mounting Block	Anodized Alum.	N/A	N/A	N/A	N/A	N/A

Technical Information

Part Number	Item	Maximum Pressure	Gas & Fluid Compatibility	Ingress Protection DIN 40050-9	Response time	Installation Torque	Weight (gms)
619260	Normally Closed Valve	1400 kPa	Natural gas and others compatible with nitrile seals	IP69K	<40 ms	30 Nm for valve body	440

